

"SL" Seal Less Motor Conversion Kit

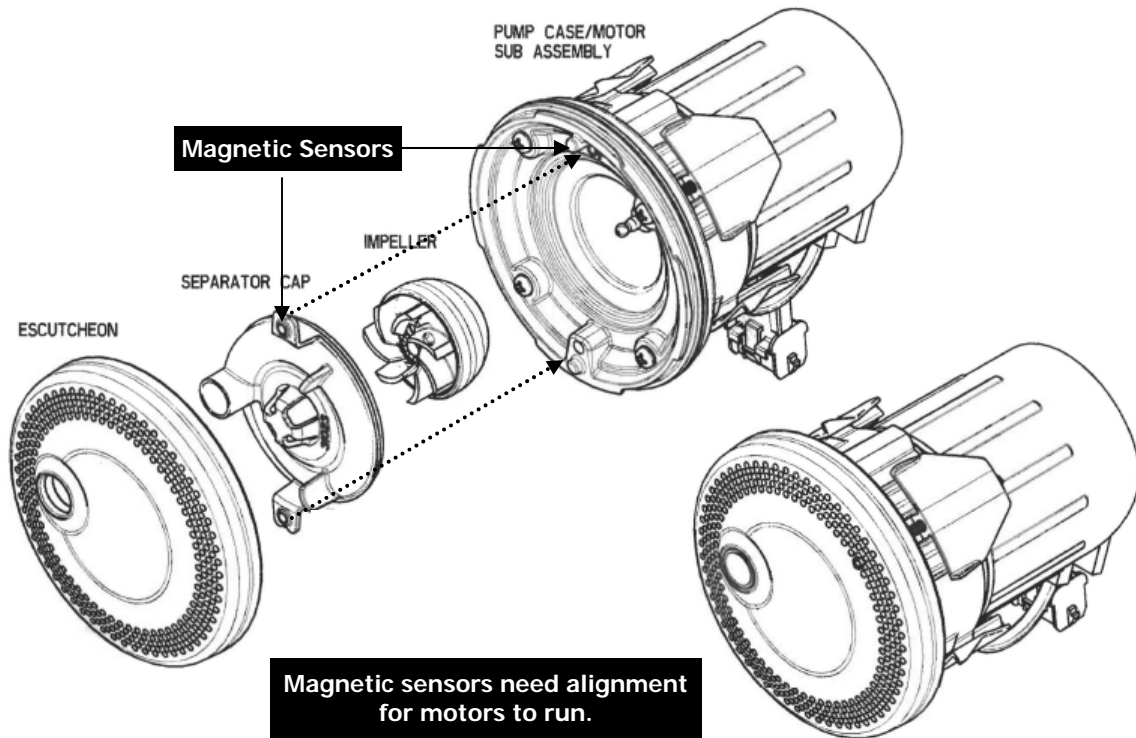

Installation Guide

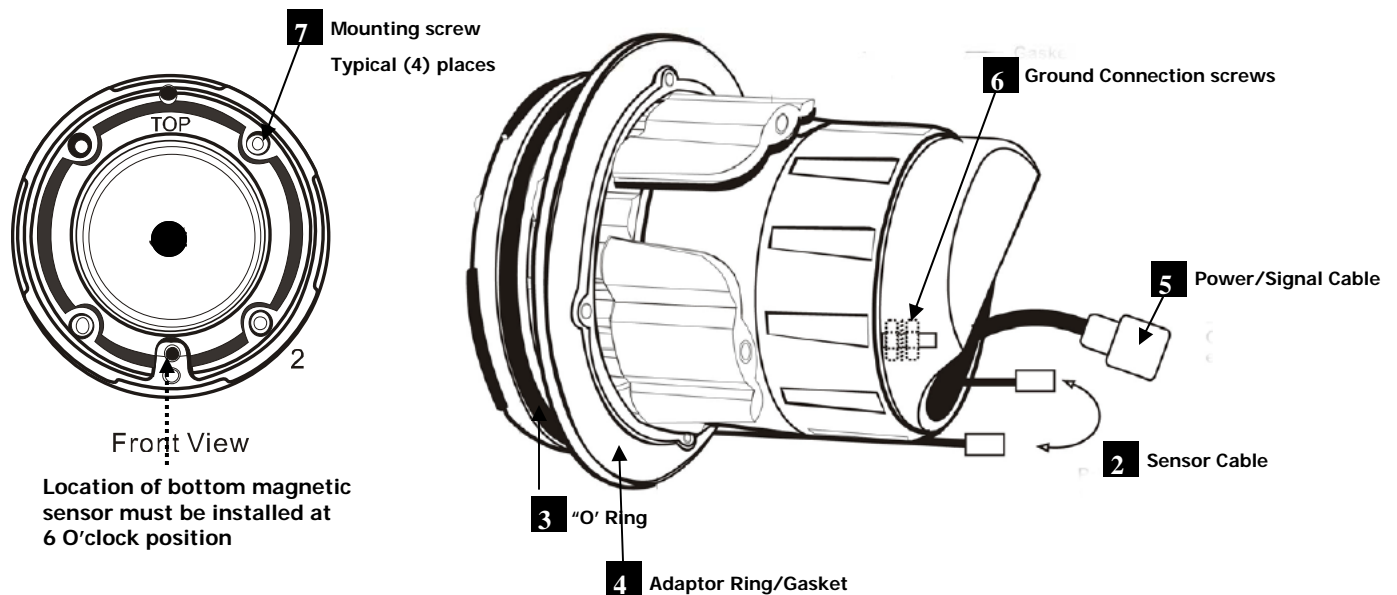

1. Remove existing "Fasco" motor and disconnect harness & ground connection.
2. Connect **Sensor cable** on the back of the motor as shown.
3. Make sure the **"O" ring** is seated properly inside the groove on the motor front casing.
4. Push **Adaptor/Gasket** against **"O" ring** to ensure tight seal.
5. Connect **Power/Signal Cable** to **Existing** harness cable.
6. Connect the green **Ground Cable** from **Existing** harness to screw located on back of motor.
7. Fasten **Mounting screws** slowly (do not to over torque) to complete installation as shown.